

Ruwisch & Kollegen

Gesellschaft mit beschränkter Haftung

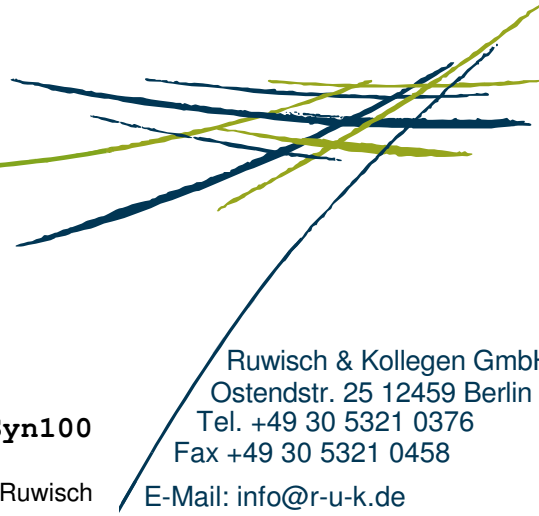

Voice Synthesis VoiceSyn100

Technical info for software package **VoiceSyn100**

Version 1.4-TI Date: 07.09.2004 Author: Dietmar Ruwisch

Ruwisch & Kollegen GmbH
Ostendstr. 25 12459 Berlin
Tel. +49 30 5321 0376
Fax +49 30 5321 0458

E-Mail: info@r-u-k.de
<http://www.r-u-k.de>

VoiceSyn100 is a high quality, very naturally sounding speech synthesis technology ideally suited for voice output at the man-machine-interface.

Ruwisch & Kollegen offer the patented technology for embedded control applications. It is the ideal solution when a user shall receive complex information but must not be distracted by displays. Running on Texas Instruments ultra-low-power Microcontroller Platform MSP430, the technology is easily integrated to any kind of customer design. The focus of **VoiceSyn100** is on applications, where the output is composed of reusable speech units, like numbers. Readily available is temperature announcement (**VoiceSyn101GE** and **VoiceSyn101EN** in English and German language). Time announcement (**VoiceSyn102EN** and **VoiceSyn102GE** in English and German language) is coming soon. Sound samples are available under www.r-u-k.de/voice. The design of a new application in any desired language is fast and inexpensive. The only condition is the availability of an appropriate native speaker of the desired language.

Technical Data (Software):

Microcontroller: TI MSP430F169
Audio Sampling rate: 11 kHz
Required Calculation Power: 4 MIPS
Required Flash memory: 60 kByte
Required Working Memory: 2 kByte
for temperature announcement 10 – 39°C

For further information please contact:

Ruwisch & Kollegen GmbH
Ostendstr. 25
D-12459 Berlin
Germany
phone +49 30 5321 0376
info@r-u-k.de, <http://www.r-u-k.de>

Texas Instruments MSP430 is the recommended hardware platform for embedded control operation of **VoiceSyn100**.

The circuit diagram below shows a schematic suggestion: Besides the Microcontroller only an amplifier is needed for voice output:

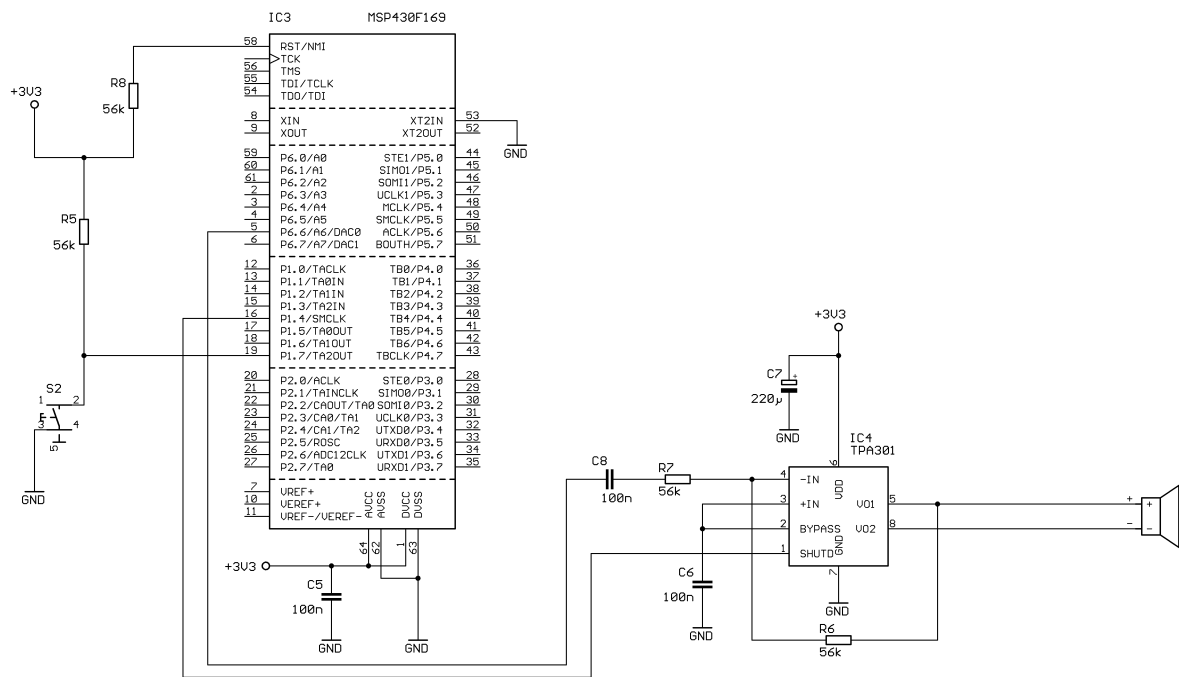

Technical Data (Hardware):

- Supply voltage: 3-5 V
- Stand-by power consumption: 0.1 µA
- Audio bandwidth: 5.5 kHz
- Resolution: 8 bit